

PARKWIND OST GMBH OWF ARCADIS OST I A01 OSS HELIDECK ON FIXED NORMALLY UNATTENDED INSTALLATION (AO OSS) EDYC		
--	--	--

REFERENCE POINT N 54° 49.04' E 013° 40.63'		
---	--	--

HEIGHT (AMSL) 120 ft	ACTUAL D-VALUE 22.2 m	MTOW 13 t
--------------------------------	---------------------------------	---------------------

WEATHER INFORMATION 7x 131.565 MHz	MCO 154.83125 MHz	LIGHT CONTROL 3 / 4 / 5x 131.565 MHz 100 / 30 / 10%
--	-----------------------------	---

CORRIDOR ORIENTATION 065° / 245°	HLD HEADING / BISECTOR 335°
--	---------------------------------------

HIGHEST OBSTACLE ON INSTALLATION (AMSL) COMPONENT MAST 159 ft	HIGHEST OBSTACLE IN THE IMMEDIATE VICINITY (AMSL) WTG OWF A01 636 ft
--	---

REFUELLING NO	EXTERNAL PWR YES	LANDING NET NO	STATUS LIGHT NO
-------------------------	----------------------------	--------------------------	---------------------------

PASSIVE FIRE-RETARDING SURFACE YES	PRIMARY SYSTEM DIFFS	SECONDARY SYSTEM 2x HYDRANTS	CO ₂ 2x 10 kg	DRY POWDER 2x 25 kg
--	--------------------------------	--	------------------------------------	-------------------------------

LIMITATIONS & NON-COMPLIANCES • NIL	REMARKS • CONTACT MCO PRIOR DEPARTURE VIA LANDLINE • FLIGHT OPS ONLY WITH CRANE RESTING CLEAR OF OBSTACLE PROTECTED SURFACES
---	--



PARKWIND OST GMBH

OWF ARCADIS OST I

A01 OSS

HELIDECK ON FIXED NORMALLY UNATTENDED INSTALLATION (AO OSS)

EDYC

OFFSHORE WINDFARM LAYOUT

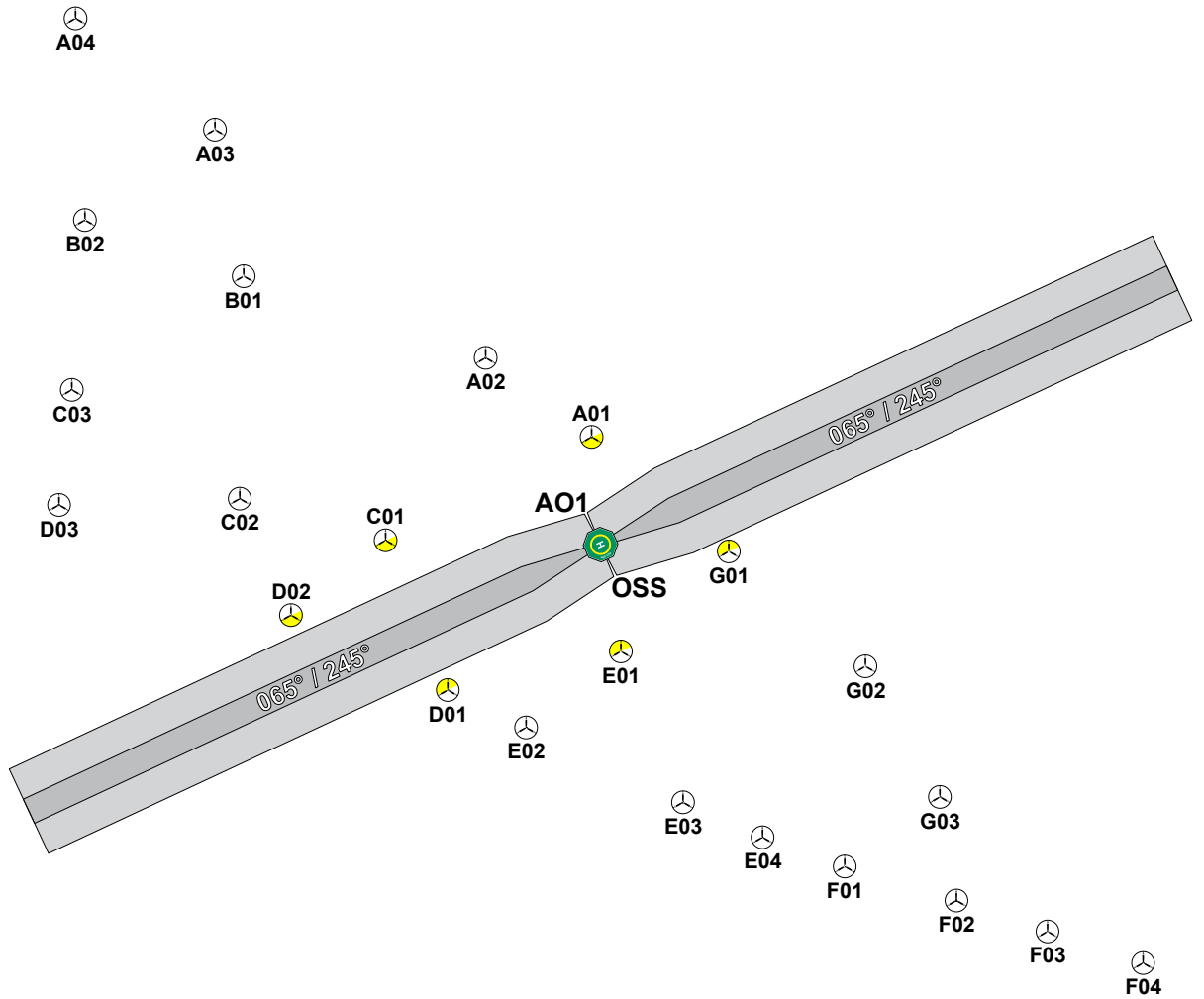

CORRIDOR ORIENTATION
065° / 245°

BISECTOR
335°



PARKWIND OST GMBH

OWF ARCADIS OST I

A01 OSS

HELIDECK ON FIXED NORMALLY UNATTENDED INSTALLATION (AO OSS)

EDYC

CORRIDOR 245°

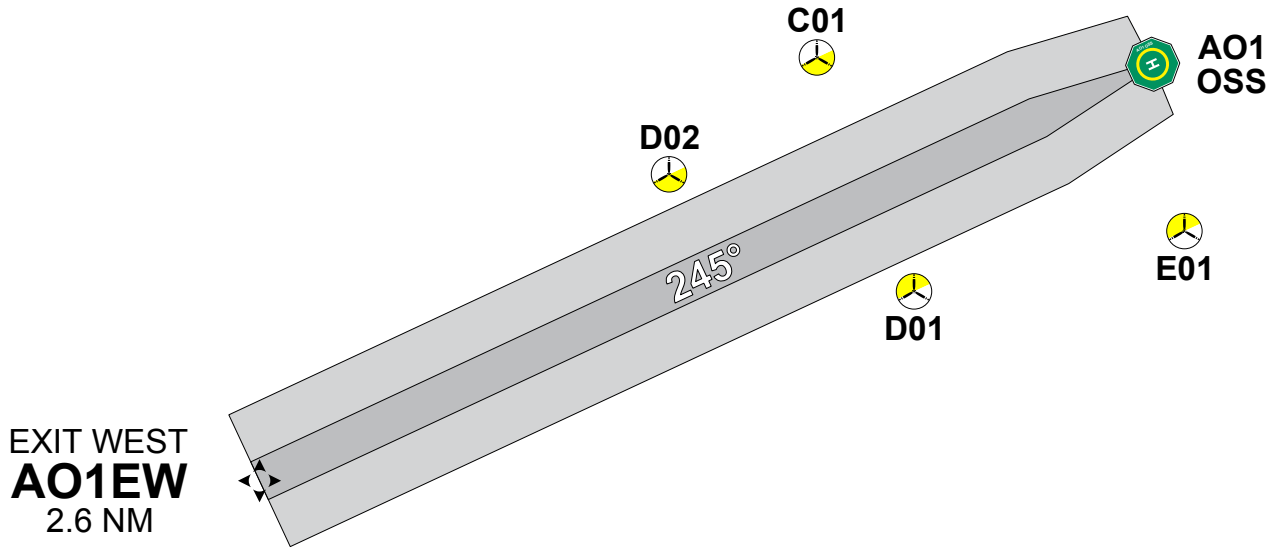

A01EW (A01 EXIT WEST)

N 54° 47.89'
E 013° 36.51'

CORRIDOR 065°

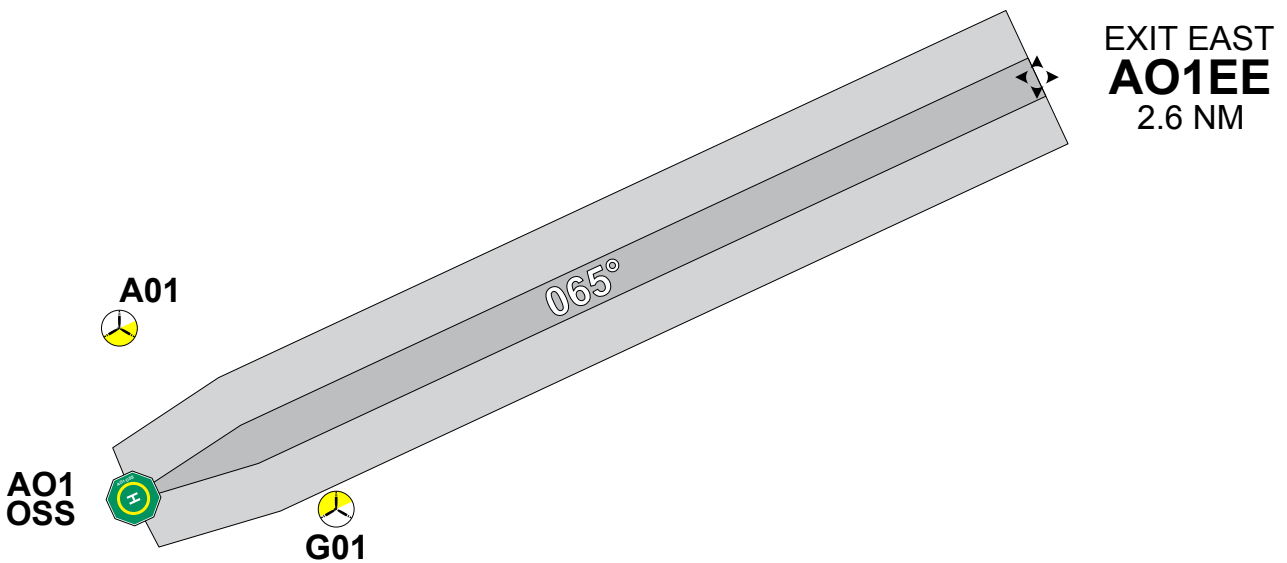

A01EE (A01 EXIT EAST)

N 54° 50.18'
E 013° 44.75'

PARKWIND OST GMBH

OWF ARCADIS OST I

A01 OSS

HELIDECK ON FIXED NORMALLY UNATTENDED INSTALLATION (AO OSS)

EDYC

TOP VIEW

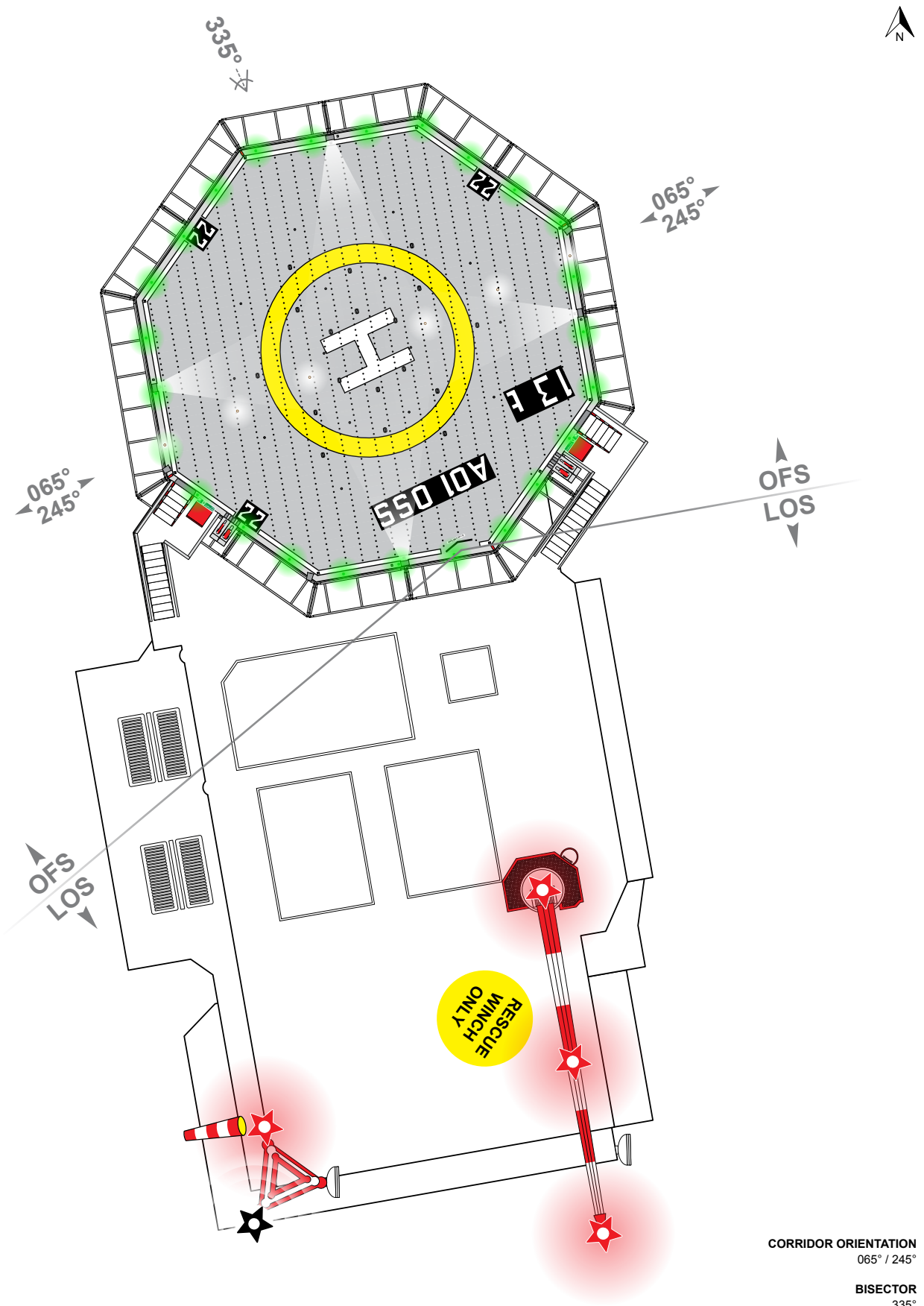

CORRIDOR ORIENTATION
065° / 245°

BISECTOR
335°

PARKWIND OST GMBH

OWF ARCADIS OST I

A01 OSS

HELIDECK ON FIXED NORMALLY UNATTENDED INSTALLATION (AO OSS)

EDYC

PROFILE VIEW (EAST)

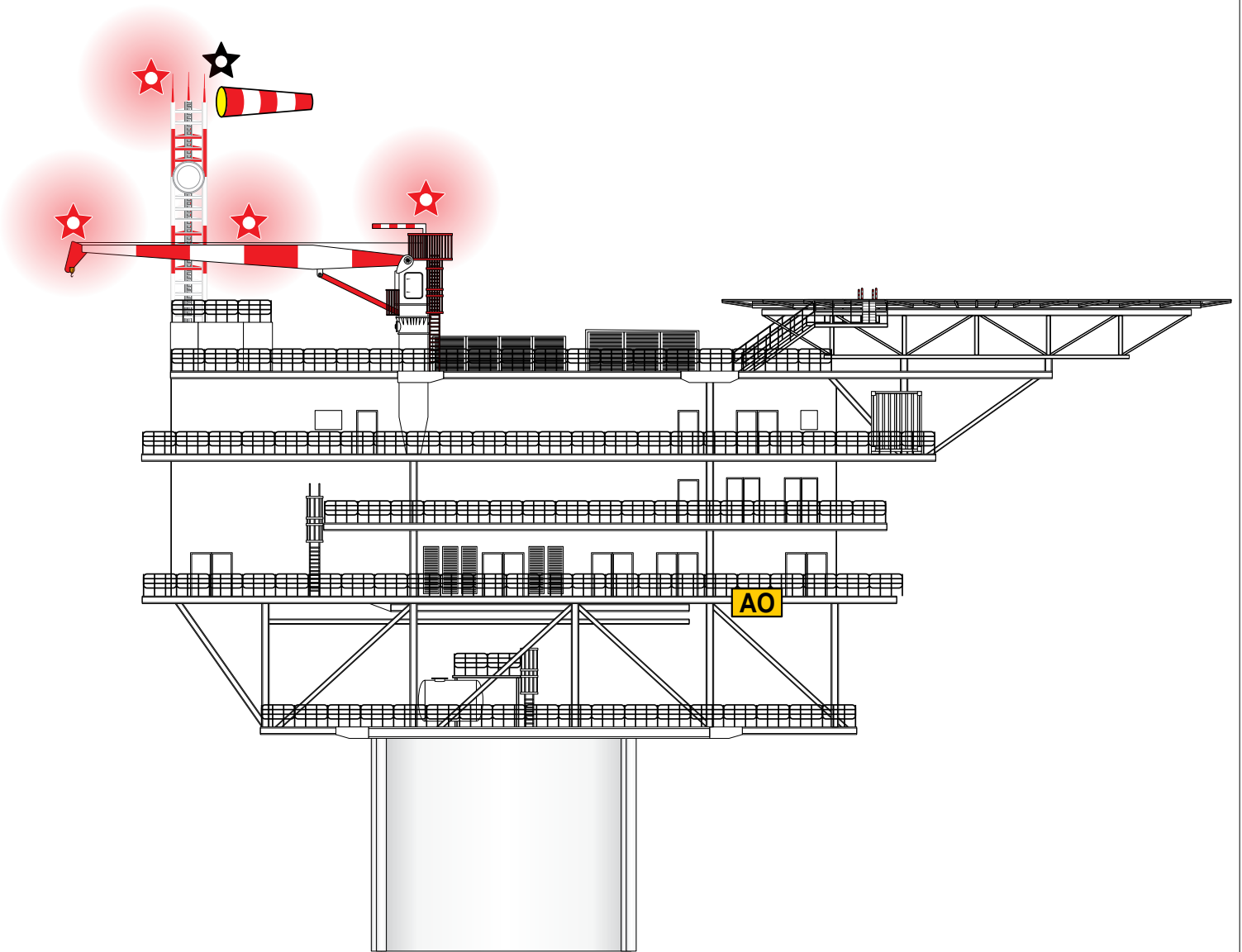

CORRIDOR ORIENTATION
065° / 245°

BISECTOR
335°